

SECTION A-A

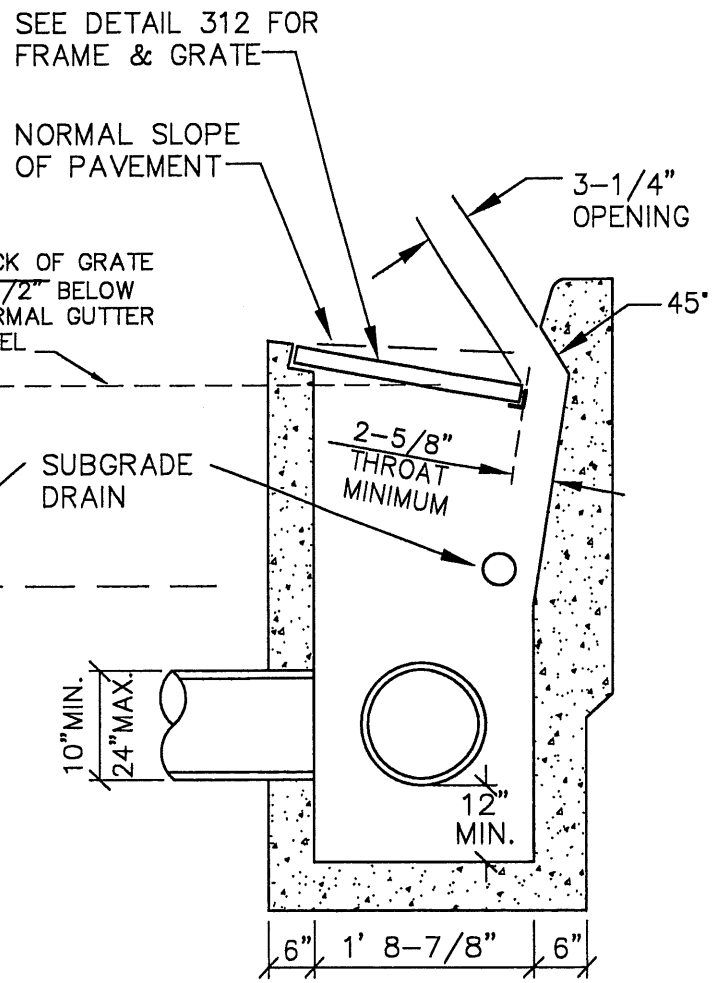

SECTION B-B

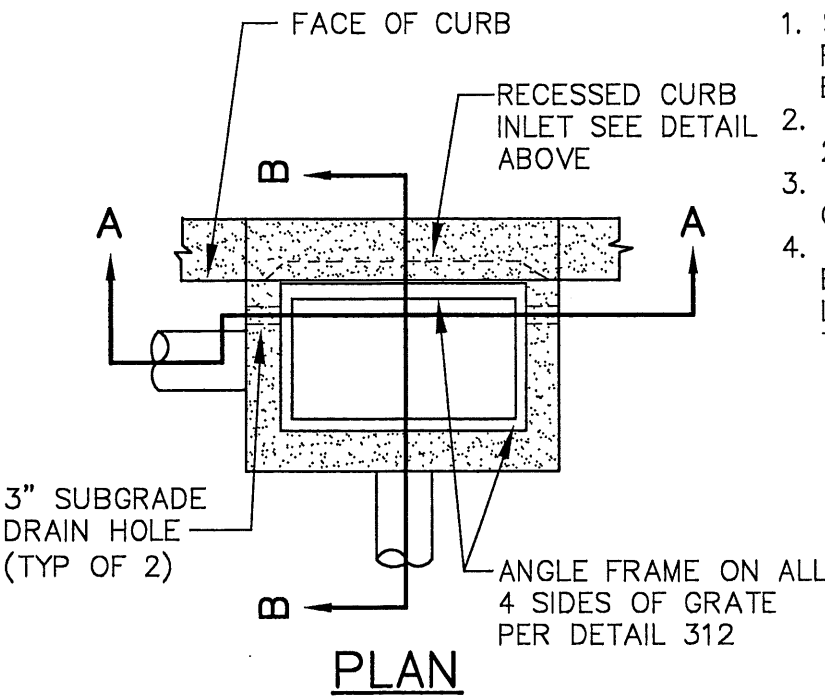

PLAN

NOTES:

1. SEE CONSTRUCTION DRAWINGS FOR PIPE SIZE, LOCATION AND INVERT ELEVATION.
2. ALL CONCRETE TO BE 3300 PSI @ 28 DAYS.
3. MATCH EXISTING CURB UNLESS OTHERWISE NOTED.
4. CURB-INLET NOTCH TO BE ELIMINATED AT DROP CURB LOCATIONS WHERE APPROVED BY THE PUBLIC WORKS DIRECTOR.

LAST REVISION DATE: NOV 2015	COPYRIGHT 1995 WESTECH ENGINEERING, INC.
STANDARD SIDE-INLET GRATED CATCH BASIN	
(NTS)	
SILVERTON, OR	DETAIL NO. 310