

CLASS 'C'
**GRAVEL SHOULDER
RESTORATION**

**WHERE ANY PORTION OF
TRENCH EXCAVATION FALLS
WITHIN SHOULDER LIMITS,
RESTORE SHOULDER FOR MIN.
WIDTH OF 36" OR AS
DIRECTED BY CITY.

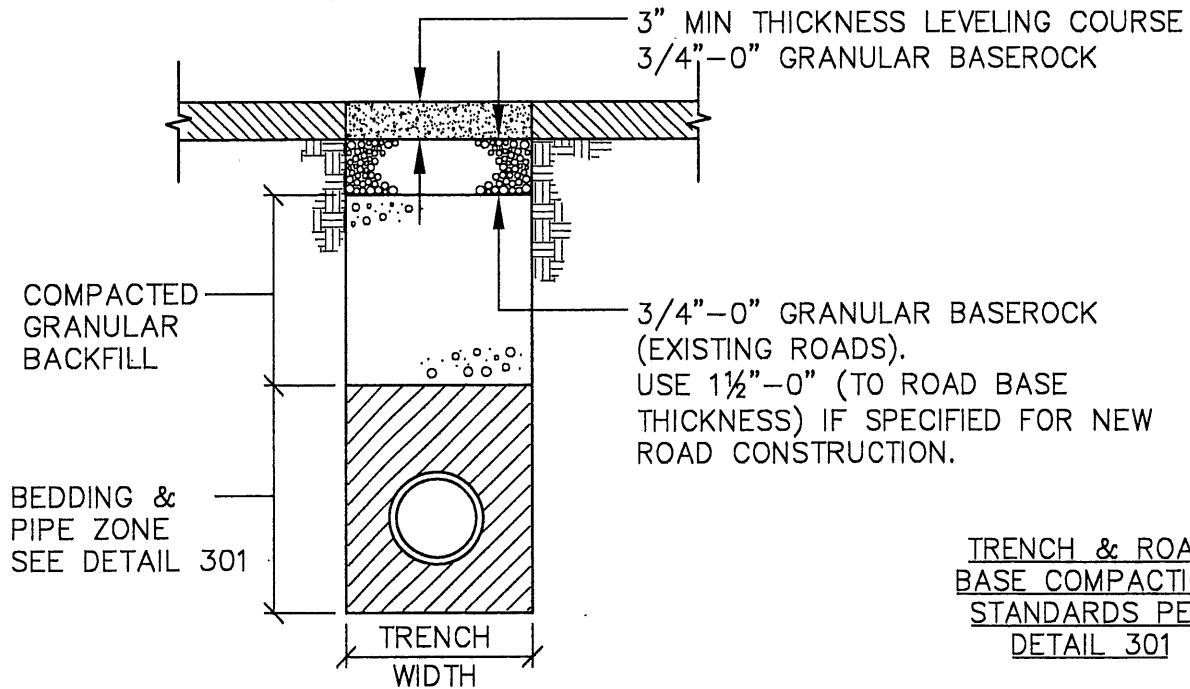

CLASS 'D'
**GRAVEL STREET
RESTORATION**

TRENCH & ROAD
BASE COMPACTION
STANDARDS PER
DETAIL 301

NOTES:

1. SHOULDER ROCK TO BE COMPACTED TO ROAD BASEROCK STANDARDS.

LAST REVISION DATE: NOV 2015	
GRAVEL SURFACE RESTORATION	
(NTS)	
SILVERTON, OR	DETAIL NO. 303