

**DOMES SHALL BE RED CONCRETE INSET PANELS
(CAST IN TACT 3 OR EQUAL)**

INSTALL TRUNCATED DOME DETECTABLE WARNING SURFACE AS SPECIFIED

SPACING: D=1.6" MIN. TO 2.40" MAX
0.65" MIN CLEAR BETWEEN DOME BASES

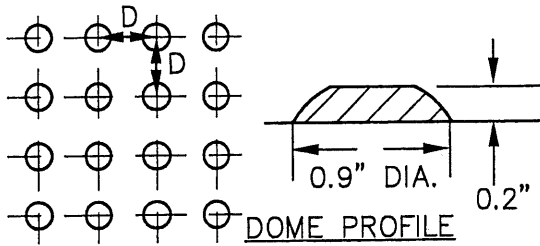
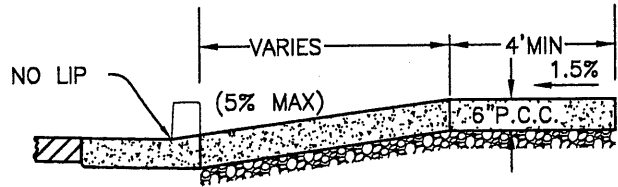
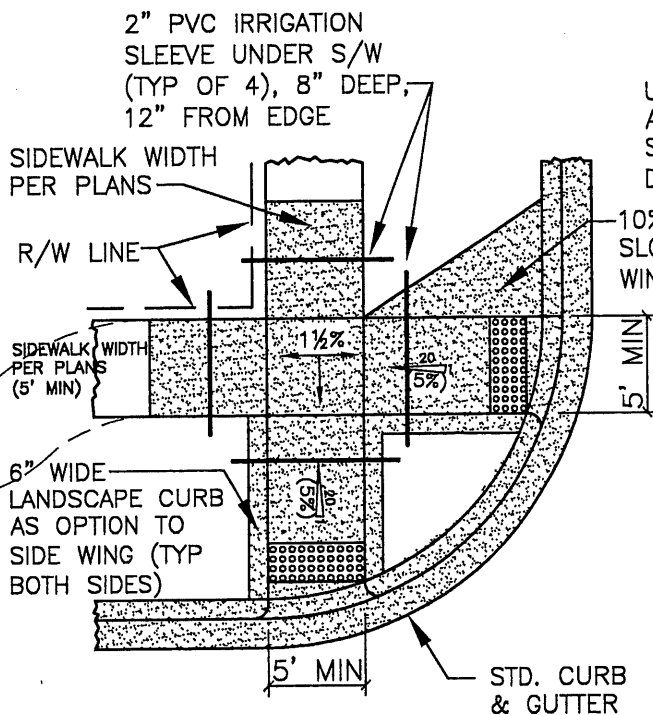

FIGURE A: TRUNCATED DOME DETAIL



SECTION



**SEPARATE RAMP FOR
PROPERTY LINE SIDEWALKS**

USE SMOOTH CURVES FOR ANY TRANSITION TO CURBLINE SIDEWALK SHOWN ON DRAWINGS (TYP)

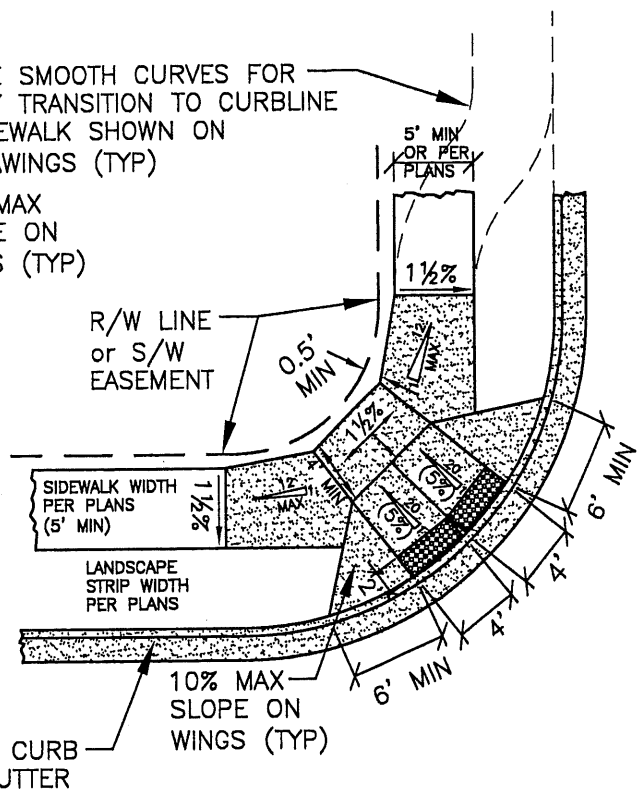

GENERAL NOTES:

1. SEE FIGURE A FOR RAMP TEXTURE DETAIL.
2. SEE TYPICAL STREET SECTIONS FOR SIDEWALK & LANDSCAPE STRIP WIDTH.
3. ALL RAMPS AND TRANSITIONS SHALL BE ADA & PROWAG COMPLIANT.
4. LANDINGS & TURNING AREAS SHALL HAVE A MIN. WIDTH & DEPTH OF 4 FEET.
5. CROSS SLOPES SHOWN ARE MEASURED FROM HORIZONTAL.
6. **SHADED SIDEWALK & RAMP AREAS TO BE CONSTRUCTED W/STREET IMPROVEMENTS, AND SHALL BE 6" THICK CONCRETE.**
7. DROP CURBS FOR HANDICAP RAMPS SHALL BE CONSTRUCTED WITH NO LIP AT THE GUTTER LINE.
8. PROVIDE 4-INCH MIN RADIUS ON ALL RETURNED CURBS.
9. DOMES PANELS TO BE MASCO CASTINTACT OR EQUAL.
10. PROVIDE 4" MIN. COMPACTED BASEROCK UNDER ALL S/W.
11. RUNNING SLOPE OF SIDEWALK APPROACH TO LANDINGS SHALL TYPICALLY NOT EXCEED 1V:12H (8.33%), BUT SHALL NOT REQUIRE THE LENGTH TO EXCEED 15 FEET.

**DOUBLE RAMPS FOR
PROPERTY LINE OR
CURBLINE SIDEWALKS
(SEE SECTION A)**

LAST REVISION DATE:	NOV 2015
INTERSECTION CURB RAMPS PROPERTY LINE SIDEWALKS LOCAL STREETS	
(NTS)	
SILVERTON, OR	DETAIL NO. 214B